

INTRODUCTION

Congratulations on your purchase of the dZ4L-C wired cycle computer by FILZER. Packed with all the features that a professional rider needs to keep track of during a workout including cadence. This computer is a perfect training tool for any cyclist.

Functions

Cadence (CAD RPM)
Average Cadence (AVG RPM)
Speedometer (SPD) (0 TO 99.9 Km/hr or M/hr)
Tripmeter (DST) (0 to 999.99 Km or M)
Odometer (ODO) (Up to 9999.9 Km or M)
Auto trip timer (TM) (99:59:59)
Maximum Speed (MXS) (0 to 99.9 Km/hr or M/hr)
Clock, 12/24 hour selectable
Average Speed (AVS) (0 to 99.9 Km/hr or M/hr)
Speed Comparator (+ or -)
Programmable Odometer
Maintenance Required Function ()
Auto Scan

BATTERY INSTALLATION

Computer - (Note: Battery is pre-installed) Remove the battery cover from the bottom of the computer using a small coin. Install the 3V battery with positive (+) pole facing the cover (Figure 1a). If the LCD shows irregular figures, take out the battery and install again. This will clear and restart the computer's microprocessor.

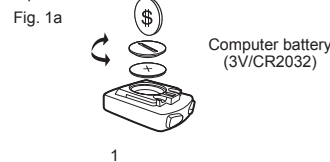

HOW TO MEASURE WHEEL SIZE

WHEEL SIZE (WS): Before you program your computer you need to determine your Wheel Size (WS). WS is the circumference of the rear wheel in mm. This value is entered into the computer in order to calculate speed and distance.

While charts provide a quick and easy way to get WS, there are no standard wheel sizes in the cycling world - i.e. the circumference (or Wheel Size = WS) of a 700x23 tire will differ from one brand of tire to another - so for accurate speed and distance values on your computer you need to measure your wheel circumference.

To obtain WS:

Method 1: Fast (and not so accurate) method - use chart provided.

Method 2: Most accurate method:

- See Figure 8.
- Inflate your tires to their proper pressure.

- Put a mark on your rear wheel on the outside circumference.
- Put a mark on the floor.
- Put the mark on the wheel on the mark on the floor.
- Rotate the wheel one full revolution until the mark on the wheel is on the floor again. Mark this location.
- Measure the distance between the marks on the floor in mm. This is the Wheel Size (WS) (i.e. your wheel circumference in mm).

h) Write this number down. The value should be between 1800 and 2200 mm for standard size tires. The unit can accommodate WS values between 100 and 5999 mm.

9

Parts

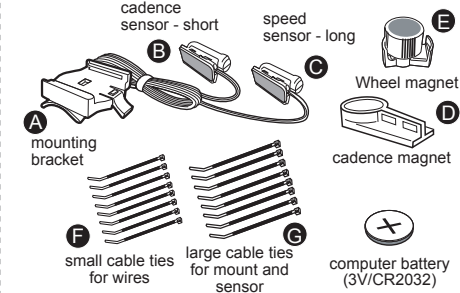

PARTS INSTALLATION LOCATION

- Area 1 - Mounting bracket (handlebar) **A**
Area 2 - Cadence sensor (left chain stay) **B**
Area 3 - Speed sensor (left chain stay) **C**
Area 4 - Cadence magnet (crank) **D**
Area 5 - Speed Magnet (rear wheel spoke) **E**

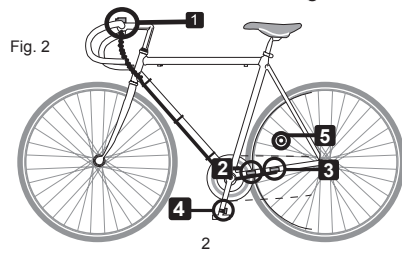

MOUNTING BRACKET INSTALLATION

Attach the mounting bracket to the right side of the handlebar with the large cable ties (Figure 3a and 3b). Make sure the mounting bracket is clamped tightly and will not slip on the handlebar. Slide the computer onto the mounting bracket until it snaps firmly into position. Press the release button to remove the computer (Figure 3c).

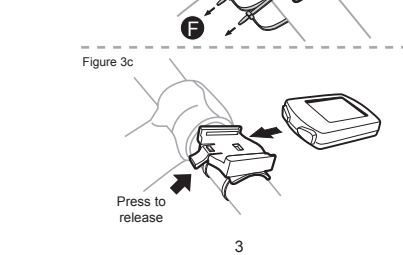
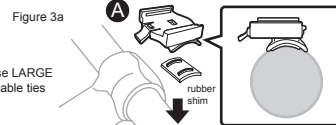

SENSORS INSTALLATION

- See Figure 4a and 4b for routing of sensors wire.
- Make sure that there is enough wire clearance so the handlebars can rotate fully in both directions without pulling at the sensors wire.
- Route the wire down the frame of your bike and to the left chain stay. Do NOT install cable ties yet.

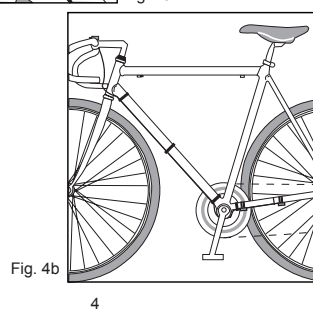
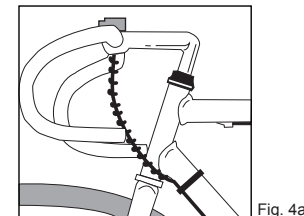

d) **Cadence Sensor** - Locate the cadence sensor (sensor with short wire). Without using cable ties - position the cadence sensor on the outside face of the left chain stay and the cadence magnet on the inside of the left crank. Position the sensor and magnet in such a way so that the magnet passes over the right portion of the sensor as shown in figure 5a and 5b.

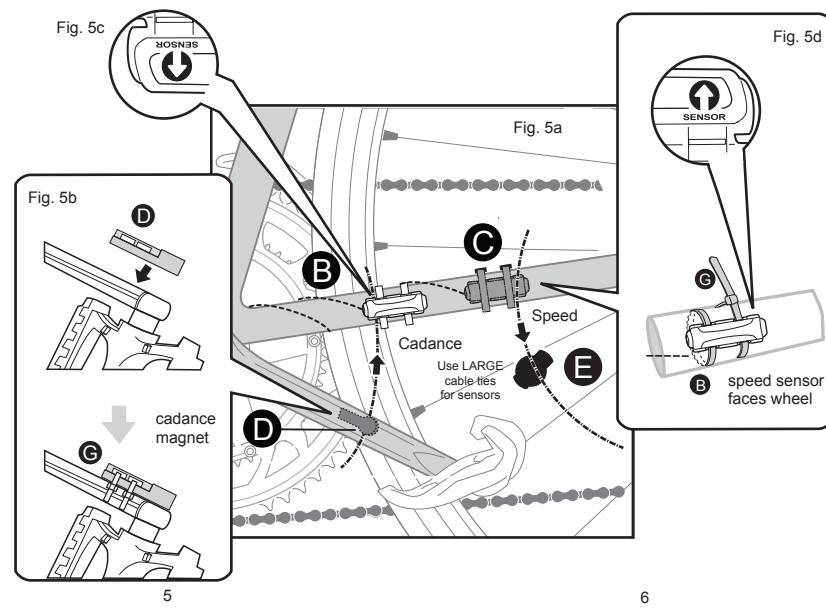

e) **Cadence Sensor** - Once you have determined the approximate position of the cadence sensor and magnet - loosely put LARGE cable ties on them. The magnet should be maximum 2mm from the cadence sensor and magnet. Note: for cranks arms that are hollow, you may need to put a spacer (not included) behind the cadence magnet to hold it in place. A small piece of foam or rolled up black electrical tape will work.

f) **Cadence Sensor** - Test out the positioning of the cadence magnet and sensor by rotating the cranks backwards to see if the computer registers a cadence value. If no value is registered reposition the sensor and magnet again. Make sure the magnet passes over circle arrow on the cadence sensor as shown in Figure 5c. Once you have positioned the magnet and sensor properly - tighten up the cadence sensor and cadence magnet cable ties securely and clip off the ends.

g) **Speed Sensor** - Locate the speed sensor (sensor with long wire). Without using tie wraps - position the speed sensor on the inside face of the left chain stay and the speed magnet on a rear wheel spoke. Position the sensor and magnet in such a way so that the magnet passes over the circle arrow on the sensor as shown in figure 5a and 5d.

h) **Speed Sensor** - Once you have determined the approximate position of the speed sensor and magnet - loosely put LARGE cable ties on the speed sensor and attach the speed magnet to the correct spoke. See Figures 6a and 6b on how to attach the speed spoke magnet. The magnet should be maximum 2mm from the speed sensor.

i) **Speed Sensor** - Test out the positioning of the speed magnet and speed sensor by rotating the rear wheel to see if the computer registers a speed value. If no value is registered reposition the sensor and magnet again. Make sure the magnet passes over circle arrow on the speed sensor as shown in Figure 5d. Once you have positioned the magnet and sensor properly, tighten up the speed sensor cable ties and ensure the spoke magnet is attached securely.

j) Secure the rest of the wire securely to the frame of your bicycle with the remaining cable ties. Make sure that there are no dangling wires.

SPEED MAGNET INSTALLATION

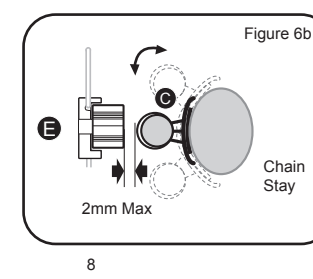
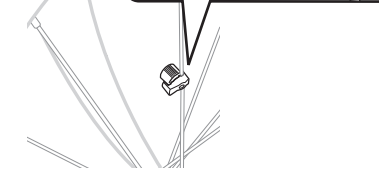
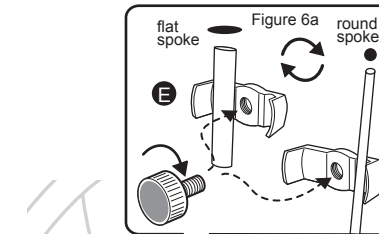

INITIAL SETUP

SETUP/RESET: In INITIAL SETUP mode you can set WHEEL SIZE (WS), KM/MILE, 12/24 hour clock and clock time. Press and hold the LEFT and RIGHT buttons for 4 seconds to access initial setup mode. The digits on the bottom row will flash - this is the WHEEL SIZE (WS) setup.

WHEEL SIZE (WS): Press the RIGHT button to adjust the value of the first digit of WS. Once you have entered the correct value press the LEFT button to advance to the next digit. Repeat for all four digits. Press the LEFT button to confirm and advance to KM/MILE setup.

KM/MILE SELECTION (12/24): Km/Miles units for distance and speed will flash. Press the RIGHT button to toggle between kilometre (KM) and miles (M). Press the LEFT button to confirm and advance to 12/24 CLOCK setup.

CLOCK (12H/24H): A 12 or 24-hour digital clock is displayed on the bottom row of the screen. Press the RIGHT key to toggle between 12 and 24 hour format. Press the LEFT button to confirm and advance to clock setup.

CLOCK: Press the RIGHT button to advance the hours (hold RIGHT button for fast advance). Press the LEFT button to confirm hours. Press the RIGHT button to advance minutes (hold RIGHT button for fast advance). Press LEFT button to confirm minutes and advance to maintenance required setup.

MAINTENANCE REQUIRED FUNCTION: A wrench icon () will be displayed and the top row digits will be flashing. The digits represent the distance interval in KM (or miles) that the wrench icon will flash to remind you to perform maintenance on your bicycle. You can choose a maintenance reminder at 200, 400, 600 and 800 KM (or miles). Press the RIGHT button to scroll between different values. Press LEFT button to confirm maintenance required value and exit setup.

ADJUSTING CLK, ODO and WHEEL SIZE (WS) VALUES AFTER SETUP: CLK, ODO and WS can be changed after setup. Go to CLK screen. Press and hold LEFT button for 5 seconds. CLK hours will flash. Press the RIGHT button to advance the hours. Press the LEFT button to confirm hours. Press the RIGHT button to advance minutes. Press LEFT button to confirm minutes and enter ODO setup. To adjust ODO value, press the RIGHT button and then press the LEFT button to confirm and select the value. Repeat this -

COMPUTER DISPLAY AND FUNCTIONS

DISPLAY: There are three main screens. Press the RIGHT button to toggle between the three display screens.

Screen 1	Screen 2	Screen 3
CAD RPM 72	CAD RPM 72	CAD RPM 72
SPD +388 KM/hr	SPD +388 KM/hr	SPD +388 KM/hr
DST 30:22	AVS 28.2	CLK 12:38
TM 0:06:24	MXS 48.8	ODO 1366.8
Cadence (RPM)	Cadence (RPM)	Cadence (RPM)
Speedometer (SPD)	Speedometer (SPD)	Speedometer (SPD)
Speed Comparator (+ or -)	Speedometer (SPD) Speed Comparator (+ or -)	Speed Comparator (+ or -)
Tripmeter (DST)	Average Speed (AVS)	Clock (CLK)
Trip Timer (TM)	Maximum Speed (MXS)	Total Distance/Odometer (ODO)

CADENCE (CAD): Current Cadence (CAD) is shown on the top row of the screen. Cadence is the rotational speed of your cranks in RPM (revolutions per minute).

AVERAGE CADENCE (CAD AVG): To see CAD AVG press the left button and Average Cadence will be displayed for 4 seconds.

SEQUENCE TO REACH THE DESIRED ODOMETER VALUE AND ENTER WS SETUP: To adjust WS value, press the RIGHT button and then press the LEFT button to confirm and select the value. Repeat this sequence to reach the desired WS value and exit setup.

TRIP TIMER (TM): Trip Timer (TM) is displayed on the bottom row. Trip Timer is activated automatically with speedometer input (when the rear wheel is turning). It records only the time spent actually riding. To reset TM to zero, go to TM screen (SCAN OFF), press and hold the LEFT button for 2 seconds. NOTE: DST and AVS will also be reset.

MAXIMUM SPEED (MXS): Maximum Speed (MXS) is displayed on the bottom row. Maximum speed is stored in memory and updates only when a higher speed is reached. To reset MXS to zero, go to MXS screen (SCAN OFF) press and hold the LEFT button for 2 seconds.

ODOMETER (ODO): Total distance traveled (ODO) is displayed on the bottom row. To adjust CLK, ODO and WS see bottom section on page 10.

SCAN MODE (SCAN): Scan mode allows you to see all screens without pressing any buttons, each screen will be displayed for 4 seconds. Press the RIGHT button until the SCAN icon is displayed on the left hand side of the 2nd row. Press the RIGHT button to stop SCAN mode - note SCAN mode is ON only when SCAN is shown on the screen.

AUTO START/STOP: The computer will start automatically when your rear wheel starts rotating. In order to conserve the battery, the computer will turn off automatically after 5 minutes.

RESET: See top section on page 10.

RESETTING: See top section on page 10.

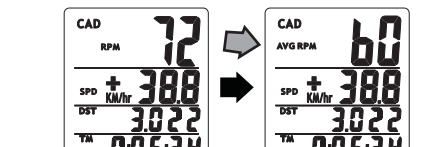

RESETTING: See top section on page 10.



TRIPOMETER (DST): Trip distance (DST) is displayed on the third row. DST is accumulated automatically with speedometer input. To reset DST to zero, go to DST screen (SCAN OFF), press and hold the LEFT button for 2 seconds. NOTE: TM and AVS will also be reset to zero.

AVERAGE SPEED (AVS): Average Speed (AVS) is displayed on the third row. AVS is calculated using the Trip Timer and Tripmeter (AVS = DST/TM). To reset AVS to zero, go to AVS screen (SCAN OFF), press and hold the LEFT button for 2 seconds. NOTE: TM and DST will also be reset to zero.

CLOCK (CLK): A 12/24 hour clock is displayed on the third row. To adjust CLK, ODO and WS see bottom section on page 10.

MAINTENANCE REQUIRED FUNCTION: The Maintenance Required Function lets you know when you need to do scheduled maintenance on your bicycle - for instance re-oil your chain after a pre-set distance is reached. The Maintenance Require Icon () will appear when maintenance is required. During setup you can set the preset maintenance reminder function to 200, 400, 600 or 800 miles (or Km). If 600 KM is chosen, the wrench will flash every 600, 1200, 1800 KM (or miles), etc. Press the LEFT button to stop the wrench () from flashing.

RESETTING: See top section on page 10.

RESETTING: See top section on page 10.

RESETTING: See top section on page 10.

RESETTING: See top section on page 10.

TROUBLE SHOOTING

Problem	Solution
No cadence reading	Verify that the cadence sensor and cadence magnet are aligned properly.
Incorrect cadence value	Verify that the cadence sensor and cadence magnet are aligned properly.
No Speedometer reading	Verify that the speed sensor and speed magnet are aligned properly.
Incorrect speedometer value	Verify that the speed sensor and speed magnet are aligned properly. Verify wheel size (WS) value.
No Trip Distance reading	Verify that the speed sensor and speed magnet are aligned properly.
Slow display response	Temperature outside of operating limits (32-125°F or 0-55°C).
Display shows irregular figures or blank screen	Re-install computer battery and verify that the computer battery is good.
Black Display	Temperature too hot or display exposed to direct sunlight too long.

ART No.: CAW-18-SJ-P3-G-FILZER(dZ4L-C)

FILZER

dZ4L-C
Wired Cycle computer with cadence
Owner's Manual

FILZER, Canada
Make in China
See www.filzer.com for other great products by Filzer

ART No.: CAW-18-SJ-P3-G-FILZER(dZ4L-C)

FILZER, Canada
Make in China
See www.filzer.com for other great products by Filzer

ART No.: CAW-18-SJ-P3-G-FILZER(dZ4L-C)

FILZER, Canada
Make in China
See www.filzer.com for other great products by Filzer

ART No.: CAW-18-SJ-P3-G-FILZER(dZ4L-C)

FILZER, Canada
Make in China
See www.filzer.com for other great products by Filzer

ART No.: CAW-18-SJ-P3-G-FILZER(dZ4L-C)

FILZER, Canada
Make in China
See www.filzer.com for other great products by Filzer

ART No.: CAW-18-SJ-P3-G-FILZER(dZ4L-C)

FILZER, Canada
Make in China
See www.filzer.com for other great products by Filzer

ART No.: CAW-18-SJ-P3-G-FILZER(dZ4L-C)