



dZ4LW3 Digital Wireless Cycle Computer Owner's Manual



INTRODUCTION

Congratulations on your purchase of the digital dZ4LW-3 wireless cycle computer by FILZER. Packed with all the features that a professional rider needs to keep track of during a workout, this computer is a perfect training tool for any cyclist.

HOW TO MEASURE WHEEL SIZE

WHEEL SIZE (WS): Before you program your computer you need to determine your Wheel Size (WS). WS is the circumference of the front wheel in mm. This value is entered into the computer in order to calculate speed and distance.

While charts provide a quick and easy way to get WS, there are no standard wheel sizes in the cycling world - i.e. the circumference (or Wheel Size = WS) of a 700x23 tire will differ from one brand of tire to another - so for accurate speed and distance values on your computer you need to measure your wheel circumference.

To obtain WS:

Method 1: Fast (and not so accurate) method - use chart provided.

Method 2: Most accurate method:

a) See Figure 8.

b) Inflate your tires to their proper pressure.

c) Put a mark on your rear wheel on the outside circumference.

d) Put a mark on the floor.

e) Put the mark on the wheel on the mark on the floor.

f) Rotate the wheel one full revolution until the mark on the wheel is on the floor again. Mark this location.

g) Measure the distance between the marks on the floor in mm. This is the wheel size (WS) (i.e. your wheel circumference in mm).

h) Write this number down. The value should be between 1800 and 2200 mm. The unit can accommodate WS values between 100 and 5999 mm.

FUNCTIONS

Speedometer (0-99.9 Km/hr or M/hr)
Tripmeter (DST) (Up to 999.99 Km or M)
Odometer (ODO) (Up to 9999.9 Km or M)
Auto trip timer (TM) (99:59:59)
Maximum Speed (MXS) (up to 99.9 Km/Hr or M/hr)
Digital Clock, 12/24 hour Selectable
Average Speed (AVS) (0-99.9 Km/hr or M/hr)
Speed Comparator (+ or -)
Speed Tendency (▲)
Odometer Program Function

BATTERY INSTALLATION

Computer - (Note: Batteries are pre-installed) Remove the battery cover from the bottom of the computer using a small coin. Install the 3V battery with positive (+) pole facing the cover (Figure 1a). If the LCD shows irregular figures, take out the battery and install again. This will clear and restart the computer's microprocessor. Similar for sensor battery (Figure 1b).

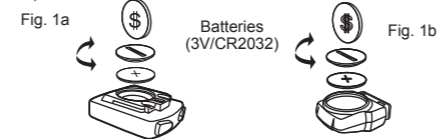

PARTS

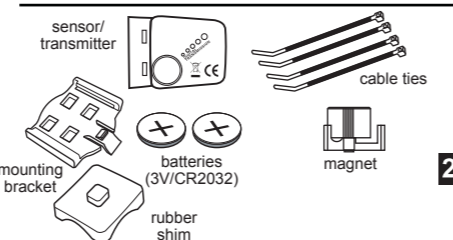

1

2

6

7

INSTALLATION

Area 1 - Mounting bracket (handlebar)
Area 2 - Speed sensor (left chain stay or seat stay)
Area 3 - Speed Magnet (wheel spoke)

a) Install the mounting bracket as per page 5.

b) See Figure 2a for position of parts on bicycle.

c) Without using tie wraps - position the sensor on the left chain stay (or seat stay) and the magnet on a wheel spoke. Position the sensor and magnet in such a way so that the magnet passes over the circle arrow on the sensor as shown in Figures 2c, 2d and 2e. Note the sensor battery cover faces inwards.

e) Once you have determined the approximate position of the sensor and magnet - loosely put the cable ties on the sensor and attach the magnet to the correct spoke. See Figures 2e and 2f on how to attach the spoke magnet. The magnet should be maximum 5mm from the sensor.

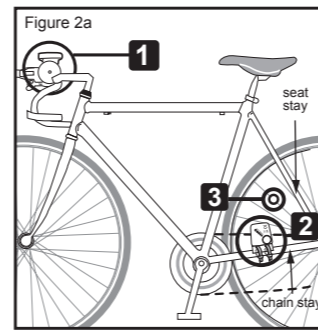

3

COMPUTER DISPLAY AND FUNCTIONS

DISPLAY: There are two main screens. Press the RIGHT button to toggle between the two display screens.

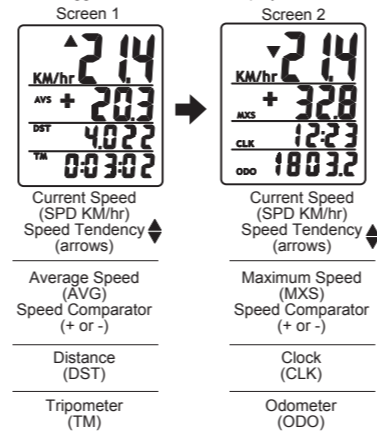

8

SYNC TRANSMITTER WITH COMPUTER: To sync the sensor with computer, start riding (at least 10 feet from other bikes) and within 45 seconds - the sensor and computer will be synced and you will get a speed value. Note - this is automatic.

f) Test out the positioning of the sensor and magnet by rotating the rear wheel to see if the computer registers a speed value. If no value is registered reposition the sensor and magnet again. Make sure the magnet passes over circle arrow on the speed sensor as shown in Figure 2d. Once you have positioned the magnet and sensor properly, tighten up the sensor cable ties and ensure the magnet is securely tightened.

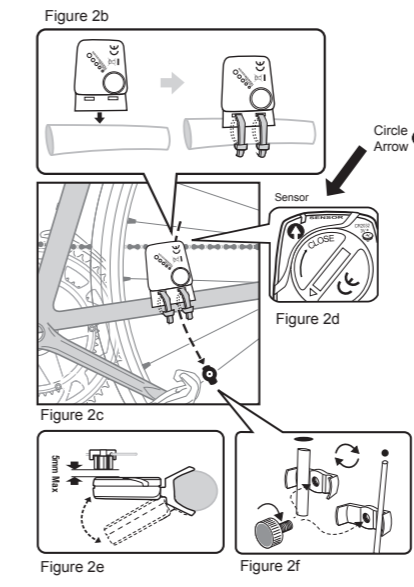

4

SPEEDOMETER (SPD): Instantaneous Speed is displayed on the first row. The range of measurement is from 0 to 99KM/hr (0 to 99M/hr) and accuracy is +/-0.5KM/hr (M/hr).

SPEED TENDENCY (▲): An "up arrow" or "down arrow" icon appears on the first row to the left of the current speed. An up arrow indicates you are accelerating. A down arrow indicates you are decelerating.

AVERAGE SPEED (AVS): AVS is displayed on the second row. AVS is calculated by dividing TM by DST. To reset AVS, press and hold the LEFT button for 2 seconds. NOTE: TM, DST and MXS will also be reset to zero.

MAXIMUM SPEED (MXS): Maximum Speed (MXS) is displayed on the second row. Maximum speed is stored in memory and updates only when a higher speed is reached. To reset MXS to zero, press and hold the LEFT button for 2 seconds.

SPEED COMPARATOR: A "+" or "-" sign appears on the second line, to the right of the SPD icon. A "+" indicates you are traveling faster than your average speed (AVS). A "-" indicates you are riding slower than your average speed.

TRIPMETER (DST): Trip distance (DST) is displayed on the third row. DST is accumulated automatically with speedometer input. To reset DST to zero, press and hold the LEFT button for 2 seconds. NOTE: TM, AVS and MXS will also be reset to zero.

CLOCK (CLK): A 12/24 hour clock is displayed on the third row. To adjust CLK, ODO and WS see bottom section on page 7.

TRIP TIMER (TM): Trip Timer (TM) is displayed on the bottom row. Trip Timer is activated automatically with speedometer input (when the wheels are turning). It records only the time spent actually riding. To reset TM to zero, press and hold the LEFT button for 2 seconds. NOTE: DST, AVS and MXS will also be reset to zero.

ODOMETER (ODO): Total distance traveled (ODO) is displayed on the bottom row. To adjust CLK, ODO and WS see bottom section on page 7

RESET: See top section on page 7.

9

MOUNTING BRACKET INSTALLATION

Attach the mounting bracket to the left side of the handlebar with the cable ties (Figure 3a and 3b). Make sure the mounting bracket is clamped tightly and will not slip on the handlebar. Slide the computer onto the mounting bracket until it snaps firmly into position. Press the release button to remove the computer (Figure 3c).

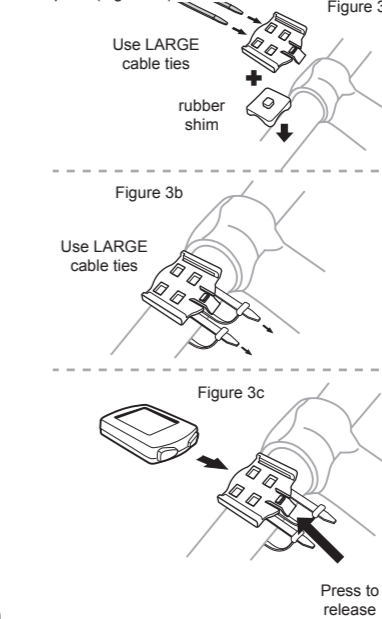

5

AUTO START/STOP: The computer will start automatically (within 1 minute) when your wheels start rotating. In order to conserve the battery the computer will turn off automatically after 5 minutes.

TROUBLE SHOOTING

Problem	Solution
Inaccurate maximum speed reading	Unknown atmospheric or RF interference. Reset Max Speed.
No Speedometer reading	Improper magnet/sensor alignment. Check magnet/sensor alignment. Verify sensor battery is good.
Slow display response	Temperature outside out of operating limits (32-125 °F or 0-55 °C).
No Trip Distance reading	Improper magnet/sensor alignment. Check magnet/sensor alignment. Verify sensor battery is good.
Display shows irregular figures or blank screen	Re-install computer battery and verify that the computer battery is good.



Filzer
Made in China
Visit www.filzer.com for more great products.

10